

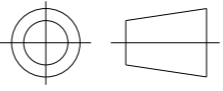

ECO. NO	REV	MARK	DETAILS	DESIGN	DATE
S19024	1		林生要求供电12V改为12~24V,更改说明书型号及料号		2019-12-18
	2		林生要求增加接线图		2020-1-13
	3		更改内容		2021-5-17
	4		更改型号		2021-8-02
	5		更改安装内容		2021-11-22
	6		更改内容		2023-08-10

Notes:

- 1. Material: 80g printing paper, white.size 290*210MM.
- 2. Printing: Black
- 3. Part number 0-ML00-3133-01-1.

	 青嵘科技有限公司 A&R Technologies LTD.									
	DIMENSION TOLERANCES UNLESS OTHERWISE SPECIFIED		CLIENT		PART NAME		英文说明书			
	<small> >0.0AND≤5 +/-0.055mm >5AND≤10 +/-0.069mm >10AND≤25 +/-0.075mm >25AND≤50 +/-0.100mm >50AND≤100 +/-0.150mm >100AND≤150 +/-0.200mm >150 +/-0.250mm Angular +/-0.25° </small>		MOULD NO		PART NO		0-ML00-3133-01-1			
			MATERIAL		REV	6	DESIGN	Chenganfu	DATE	2023-08-10
			SIZE		A4	SCALE	CHECK		DATE	
			SHEET		UNIT	mm	APPROVAL		DATE	

HBOD-0608/1216 D124

Operation and Specifications

HBOD-0608/1216 D124 is a patented HDIR[®] occupancy motion sensor with Suren's proprietary multi-segment lens array. Mounted at a height of maximum 6m or 12m.

Parameter Setting:

The sensor becomes operation 30 seconds after power on
LED indicator:
 led flashes upon power up
 led should turn on 3~5 seconds when motion is detected by infrared sensor.

PRODUCT MODEL

HBOD-0608D124

HBOD-1216D124



SPECIFICATIONS

	HBOD-0608D124	HBOD-1216D124
Range	8m	16m
Mounting height	3~6m	6~12m
Operating voltage	+12~24V DC	+12~24V DC
Bluetooth range	20m	20m
Lux Sensor	1~4000Lux	1~4000Lux
Delay-offtime	1s~30Min	1s~30Min
Operating temp	-40~60°C	-40~60°C
Waterproof standard	IP65	IP65
Measurement	Φ80mmx80mm	Φ80mmx80mm

WIRING DIAGRAM

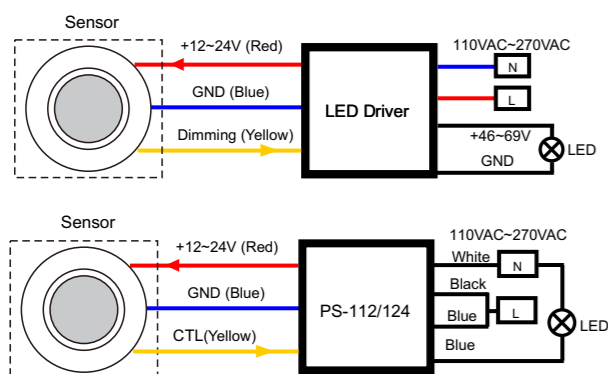

Noted:

Each PS-124/224 power maximum one HBODXXXXD124 and PS-112/212 power maximum three HBODXXXXD124.

OPTICAL VIEW PATTERN

HBOD-0608(mounting height :6m)

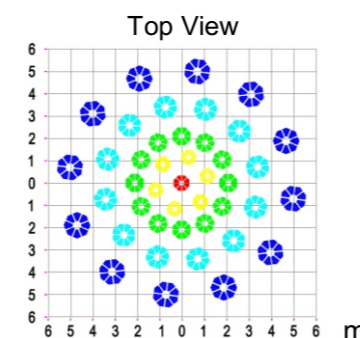
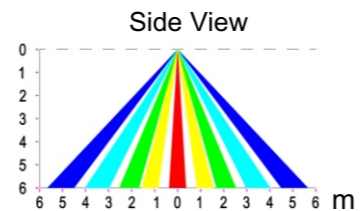

HBOD-1216(mounting height :12m)

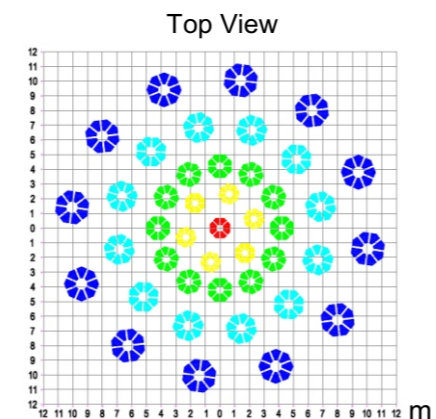
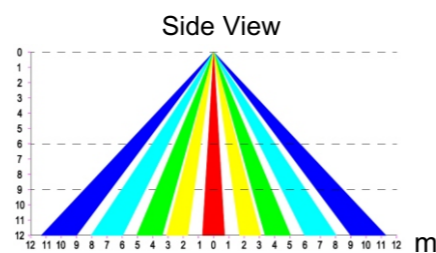

INSTALLING APP

Download from App store for BTR_OCC or Scan QR Code below.



(Android)



(IOS)

Require IOS version 8.0 or above, Bluetooth version 4.3 or above.

APP HOME PAGE (fig.1)

WALK TEST: To check the detection range and sensitivity of occupancy sensor.

DEVICE SETTINGS: Names/ID, password, sensitivity, lux-level, off-time delay.

HELP: Product related information

SEARCH: " 🔍 "

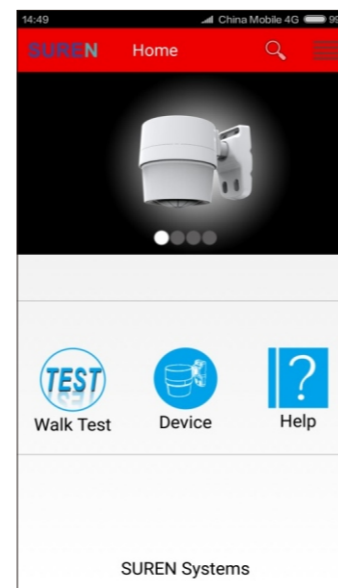

fig.1

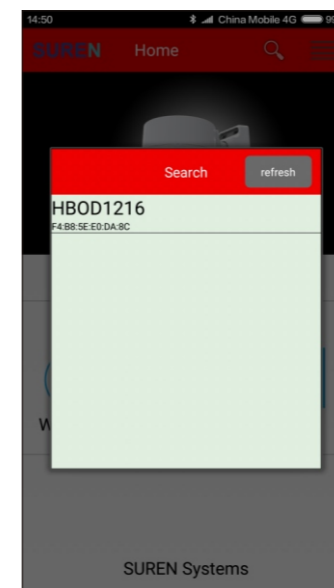

fig.2

BLUETOOTH PAIRING (fig.2)

From the APP home page, tab in " 🔍 " a dialog frame will appear, enter the original password "000000" to complete pairing.

APP FEATURES

WALK TEST: From the home page tab in (walk test) to test occupancy sensor function, during this test mode, lux sensor is disabled; delay-off-time is set at 3 seconds. When motion is detected by sensor, a walking figure symbol (fig.4) is displayed on screen. When no motion is detected, a still (fig.3) figure is shown on the screen. Slide the switch to OFF to exit..

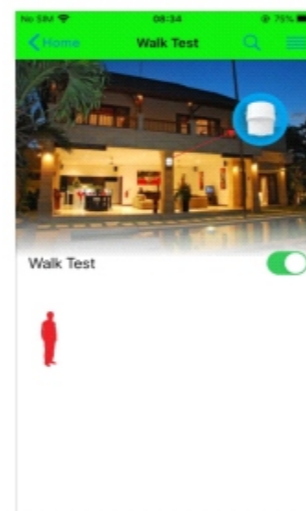

fig.3

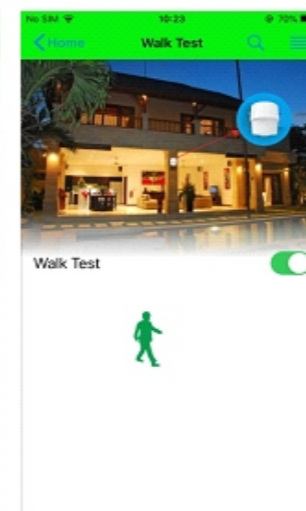

fig.4

DEVICE SETTINGS: From the home page, tab in DEVICE to set the parameters. (fig.5 & fig.6).

●Change/prescribe names/ID: enter new names/ID in the frame, press "Enter" to save.

●LED driver: Select 'On' if LED driver is being used, select 'Off' if LED driver is not being used.

Note: preferred light level and cut-off light level settings are available only when LED driver is used, i.e. when there is dimming control to the lights.

●Preferred light level: To set the Turn-on brightness (70-100% brightness).

●Cut off light level: To set the Turn-off brightness (0-30% brightness).

●Sensitivity: Choices of High/Medium / Low for occupancy sensor.

●Operating lux level: To turn light on at desired ambient light level, slide lux level indicator left or right.

●Delay-off time: To set the duration of the light from 1s-30min, slide indicator left to right to choose.

Factory preset:

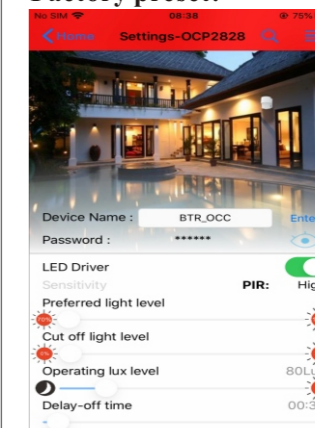

fig.5

Preferred light level: 70%
 Cut off light level : 30%

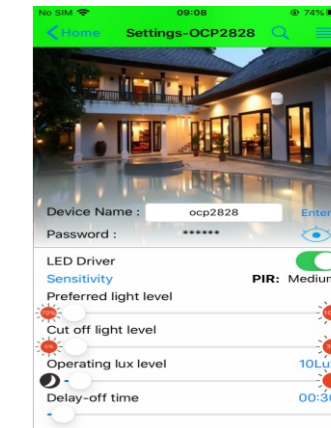

fig.6

Operating lux level: 80 Lux
 Delay-offtime : 30S

● Password setting - Tab in password frame, enter the original/old password (000000), then enter the new 6-digits password (xxxxxx), confirm new password again, press "Save" exit page. (fig.7).

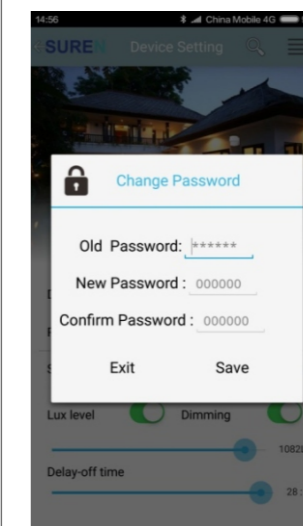

fig.7

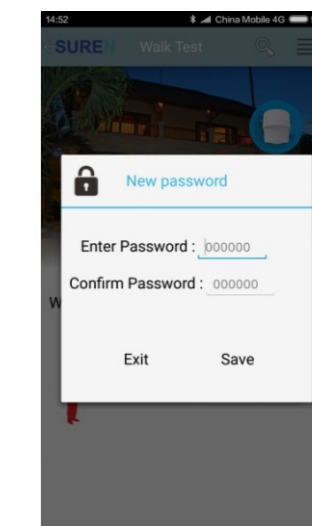
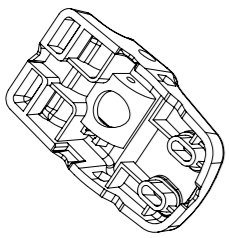



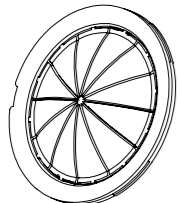
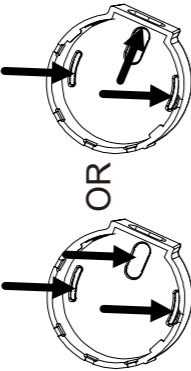
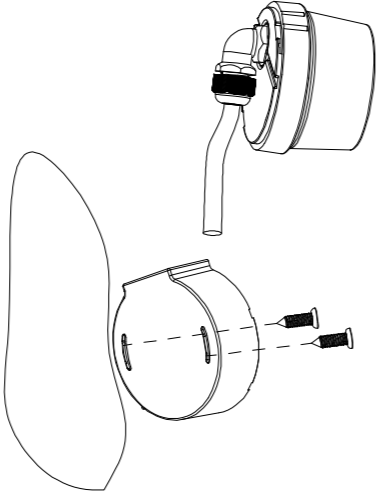
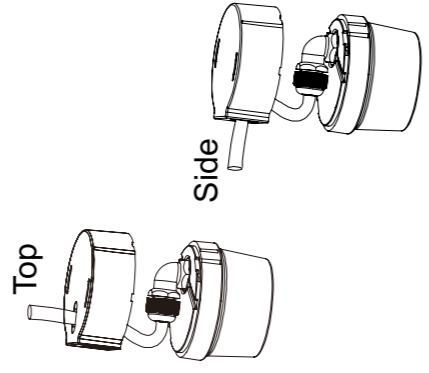
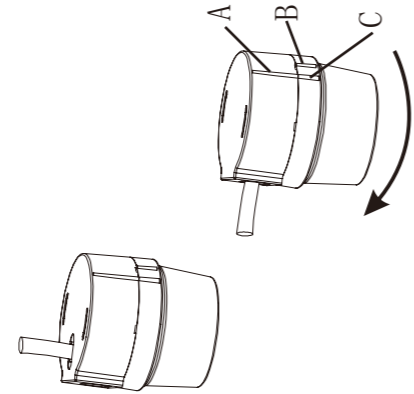
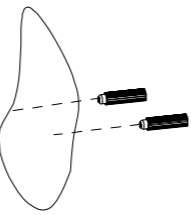

fig.8

To reset password:
 Disconnect power to the sensor, re-connect power and set a new password within 5 minutes upon power up as according to password setting procedure above (fig.8).

 <p>Mounting Bracket x1</p>	 <p>M22*1.5 Plastic Lock Nut x1</p>	 <p>Adapting insert x1</p>	<p>Φ6*27 Wall plugs x2</p> 	<p>M3*20 Countersunk head screw x1</p> 	 <p>Lens mask x1</p>
--	--	---	--	--	---

◆Installation:
Ceiling mount

<p>① Knock-out holes for wires and screws.</p> 	<p>③ Mounting the top cover with screws(E).</p> 	<p>④ Pull wires through the knockout hole.</p> 	<p>⑤ Align marking A to B and turn the housing to align A,C to secure.</p> 
<p>② Apply wall plugs (D).</p> 			

Wall mount

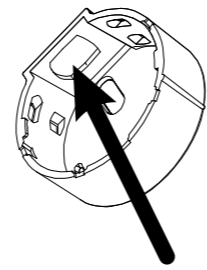
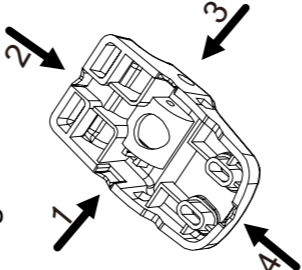
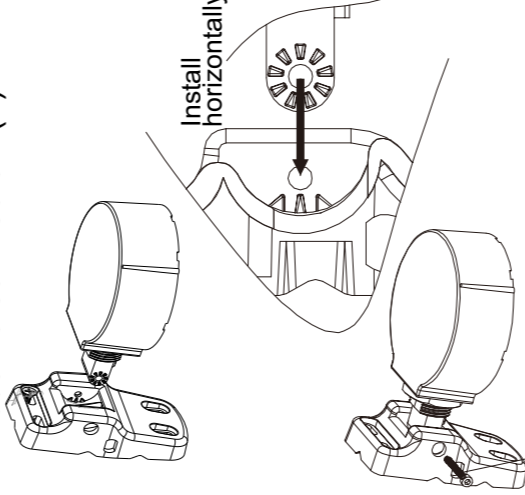
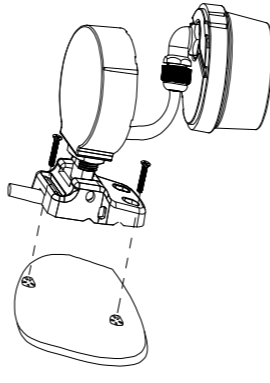
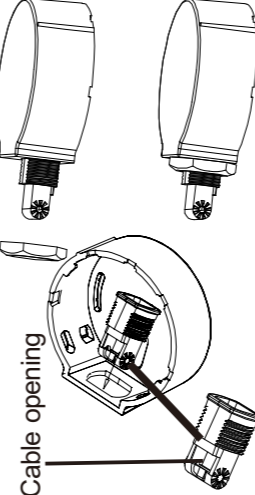
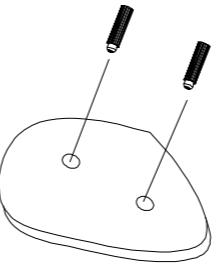
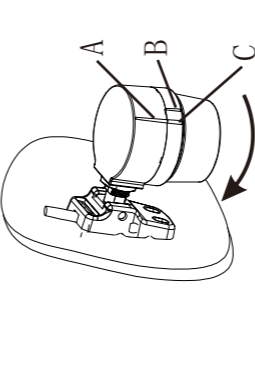
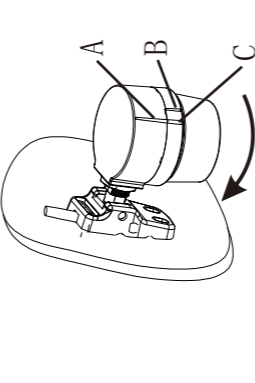
<p>① Knock out hole for adapting insert(C).</p> 	<p>③ Bracket (A) knockout wire through hole.</p> 	<p>⑤ Secure the Top cover to the wall Bracket with M3*20 countersunk screw (F).</p> 	<p>⑥ Secure the Bracket (A) with screws (E).</p> 
<p>② Install the adapting insert(C) to the top cover,secure it with Lock Nut(B).</p> 	<p>④ Apply wall plugs (D).</p> 	<p>⑦ Align marking A to B and turn the housing to align A,C to secure.</p> 	<p>⑦ Align marking A to B and turn the housing to align A,C to secure.</p> 

Sensor head adjustment

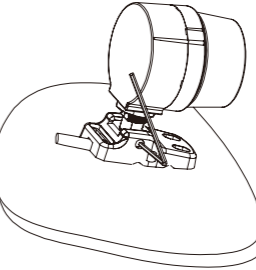
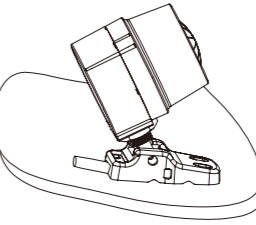
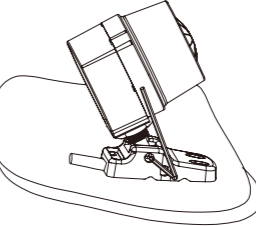
<p>① Secure and loosen M3*20 (F) screw with Hex screw driver.</p> 	<p>② Adjust the head up.</p> 	<p>③ Tighten M3*20(F) screw.</p> 
---	---	--

Masking Lens installation

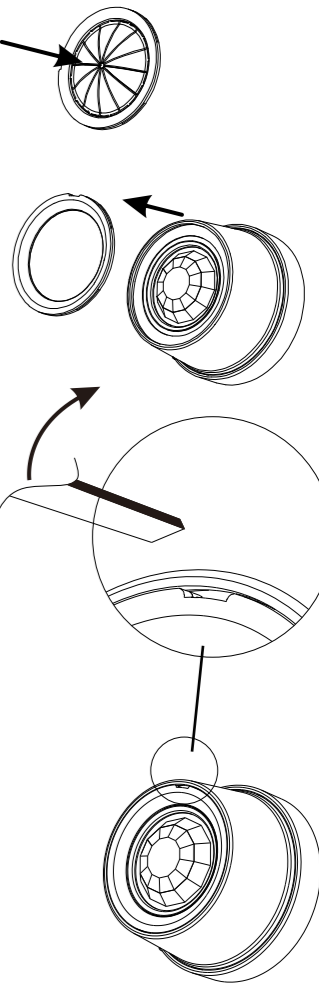
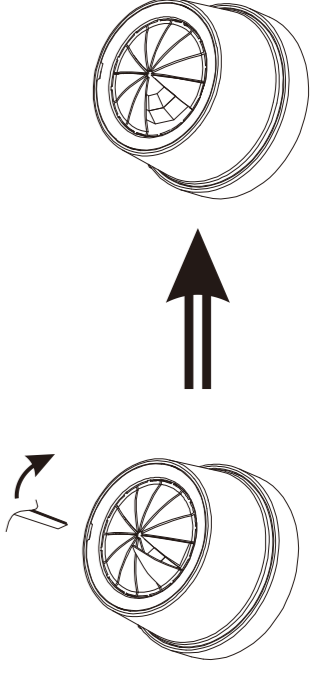
<p>① Remove the Lens RIM and replace it with Lens mask (G).</p> 	<p>② Remove segments as desired.</p> 
---	--