

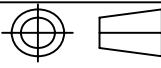

ECO.NO	REV	MARK	DETAILS	DESIGN	DATE
	1		首次发行	范绮玲	2020-1-7
	2		增加mask接线端口	程安福	2020-11-10
	3		更改视区图	程安福	2021-07-26
	4		更改内容	程安福	2021-08-09
	5		更改内容	程安福	2023-02-27
	6		更改内容	程安福	2023-06-30

Notes:

1. Material: 80g printing paper, white.size 297*210MM.
2. Printing: Black
3. Part number 0-ML00-3082-01-1.

	 青嶸科技有限公司 A&R Technologies Ltd.							
	DIMENSION TOLERANCES UNLESS OTHERWISE SPECIFIED		CLIENT	PART NAME		英文版说明书		
	>0.0AND≤5	+/-0.055mm	MOULD NO	M-6815AM	PART NO		0-ML00-3082-01-1	
	>5AND≤10	+/-0.060mm	MATERIAL	REV	6	DESIGN	程安福	DATE
	>10AND≤25	+/-0.075mm	SIZE	/	SCALE	/	CHECK	DATE
	>25AND≤50	+/-0.100mm	SHEET	UNIT	mm	APPROVAL	DATE	
>50AND≤100	+/-0.150mm							
>100AND≤150	+/-0.200mm							
>150	+/-0.250mm							
Angular	+/-0.25°							

M-6815AM DFIR™ Motion Sensor

Operation and Specifications

SUREN

The M-6815AM a professional state-of-the-art motion sensor engineered with the world's best components and materials. Every aspect of these sensors provides the most reliable motion sensing with freedom from false alarms. M-6815AM include two motion sensing systems: microwave Doppler motion sensing and DFIR™ motion sensing, with directional motion sensing to reject false alarms caused by swaying objects. Together, the two systems' signals are evaluated by proprietary signal processing algorithms, which reject false alarm conditions while detecting intruders.

The M-6815AM microwave system includes a modern, compact, DRO-based micro-strip Doppler transceiver, with PCB "patch" antennas. The Doppler signal is digitally processed to detect intruders and reject distractions. Constant-motion signals (such as fans) are de-emphasized, and fluorescent light frequencies are digitally removed. The optical side starts with a EvenEye™ lens and a top-quality specially-designed DFIR™ infrared detector. Next, a modern microcontroller converts the infrared detector signal into digital form, for best reliability and stability. Finally, the signal is evaluated with DFIR™ anti-sway processing, for "best-in-class" false alarm rejection with excellent intruder detection.

ANTI-SWAY FUNCTION

The M-6815AM is a motion sensor, and it will normally detect swaying motion. However, the outdoor environment may contain swaying objects that are not intruders (for example, wind-blown trees). Thus, to suppress "nuisance alarms", the M-6815AM provides an "anti-sway" function to require that, before motion is indicated, a moving object must make directional progress across the sensor's fields of view. This function can be enabled or disabled by DIP.7. Naturally, when enabled, a longer motion in front of the sensor is required before a motion Alarm is indicated. See Installation Instructions steps 8 and 9 for details.

SENSOR INITIALIZATION

Following power-on, M-6815AM Motion Detector sensor is fully operational after a two-minute warm-up. During warm-up, the red Alarm LED is ON.

WALK TEST: (RED LED)

Note: The M-6815AM should be tested once per year.

In Normal Operating Mode: Enable the LEDs (DIP.10 ON). If the Alarm LED is not enabled, then, set DIP.10 to ON, remove power and re-instate power. Walk across the monitored area (within the sensor's optical fields-of-view). With anti-sway disabled, and with sensitivity set at STANDARD, the red Alarm LED should turn ON (for Alarm) after about three to five normal steps. With the sensitivity set at HIGH, the LED should turn ON (for Alarm) after about two to four normal steps. Each time the LED turns ON, wait for it to turn OFF. Then, wait 12 seconds before continuing the walk-test. When there is no motion in the monitored area, the LED should remain OFF.

In Special Modes: Cycle power-off/power-on, then Walk-test immediately after warm-up in the 30-minute walk-test mode.

SINGLE-SYSTEM TEST: DFIR (Green LED), MICROWAVE (Yellow LED)

The function of each motion sensing system can be monitored separately during the first 30 minutes after power-on. To test the DFIR system, walk across the monitored area (within the sensor's optical fields-of-view). Each time a field-of-view is entered, the green LED should flash. To test the microwave system, move within the monitored area. During movement, the yellow LED should flash. In this mode, the red LED indicates Alarms. Adjust RV1 to change microwave detection sensitivity as required. 30 minutes after power-on, the yellow and green LEDs will be disabled.

PET IMMUNITY

The M-6815AM is designed to allow the presence of pets (15kg or lighter) without signaling an alarm. Some pets, especially larger ones with short hair, even if higher than 15kg may produce enough infrared radiation to cause alarms. It's highly recommended to test the sensor with individual pets, in order to confirm lack of alarm, See the next diagram.

SUPERVISION

M-6815AM supervision functions :

Detector electronics okay;

When a failure is detected, then:

- 1) The red alarm LED blinks ON/OFF every second.
- 2) Alarm relay does not re-close after an alarm signal event.

NOTE : The sensor will NOT initiate an alarm upon failure.

SUREN LIMITED WARRANTY

Limitations of Security Products: Security products and alarm systems do not offer guaranteed protection against burglary, fire, or other emergencies. They may fail to warn for diverse reasons, including (but not limited to): power failure, dead batteries, improper installation, coverage "blind spots", coverage areas overlooked during installation, defeat by technically sophisticated intruders, component failure, or inadequate maintenance. Alarm systems should be checked weekly to ensure that all devices are working properly. AN ALARM SYSTEM IS NOT A SUBSTITUTE FOR INSURANCE.

SUREN Systems, Ltd., of Fo Tan, Shatin, Hong Kong, warrants its products to be in conformance with its own plans and specifications and to be free from defects in materials and workmanship under normal use and service for twelve months from the date of original purchase. Seller's obligation shall be limited to repairing or replacing, at its option, free of charge for materials or labor, any part which is proved not in compliance with Seller's specifications or proves defective in materials or workmanship under normal use and service. Seller shall have no obligation under this Limited Warranty or otherwise if the product is altered or improperly repaired or serviced by anyone other than Seller. For warranty service, return transportation prepaid, to SUREN Systems, Ltd., Unit 15, 12/F, Block B, Wah Sang Industrial Building, 14-18 Wong Chuk Yeung Street, Fo Tan, Shatin, Hong Kong. Seller has no obligation to attend the buyer's location to retrieve the goods or make repairs on site.

There are no warranties, expressed or implied, of merchantability, or fitness for a particular purpose or otherwise, which extend beyond the description on the face hereof. In no case shall seller be liable to

SPECIFICATIONS

Range: 15 meters in sensor-facing direction
15 meters at 45° angle from sensor-facing direction

Sensor Optical View Pattern (side view, in meters)

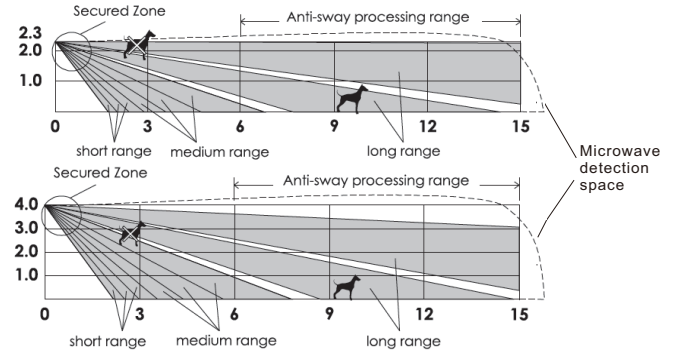

Optical Fields-of-View:

Long-range	Mid-range	Short-range
88	38	26

Sensor Optical View Pattern (top view, in meters)

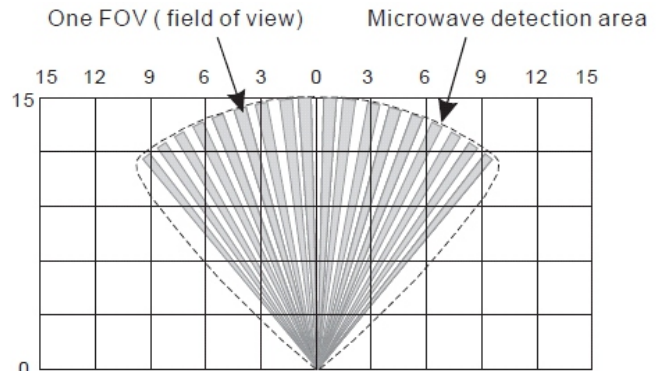

IR Sensors (2):
Dual-element + Quad-element

Power Supply:
8-16 Vdc; 30 mA at 12 Vdc

Alarm Relay:
Solid state, Form A (NC). 50 mA at 30 Vdc, 1500 V_{rms} isolation

Mask Relay:
Solid state, Form A (NC). 50 mA at 30 Vdc, 1500 V_{rms} isolation

Tamper Switches (cover/wall):
Form A (NC). 50 mA at 30 Vdc

Housing Material:
PC housing, HDPE lens

Dimensions:
171 x 76 x 61 mm (H x W x D)

Approvals/qualification:

CE

Microwave Operating Freq:
Around 10 GHz. See unit label

Events Detection:
DFIR™ anti-sway false alarm rejection processor

RF Immunity:
20 V/m, 10-1000 MHz;
10 V/m, 1-2 GHz

Sensitivity: DFIR
Selectable: short-walk or long-walk

Operating Temperature Range:
-30°C to +55°C (-22°F to +131°F)

Storage:
-40°C to +60°C (-40°F to +140°F)

ACCESSORIES OPTIONS

Mounting bracket: MB-200

Anti-masking:
Order Model M-6815AM

Note: Specifications are subject to change without notice.

anyone for any consequential or incidental damages for breach of this or any other warranty, express or implied, or upon any other basis of liability whatsoever, even if the loss or damage is caused by its own negligence or fault.

Seller does not represent that the products it sells may not be compromised or circumvented; that the products will prevent any personal injury or property loss by burglary, robbery, fire or otherwise; or that the products will in all cases provide adequate warning or protection. Customer understands that a properly installed and maintained alarm system may only reduce the risk of a burglary, robbery, or fire without warning, but it is not insurance or a guarantee that such will not occur or that there will be no personal injury or property loss as a result.

Consequently, seller shall have no liability for any personal injury, property damage or other loss based on a claim the product failed to give any warning. However, if seller is held liable, whether directly or indirectly, for any loss or damage arising under this limited warranty or otherwise, regardless of cause or origin, seller's maximum liability shall not in any case exceed the purchase price of the product, which shall be the complete and exclusive remedy against seller.

This warranty replaces any previous warranties and is the only warranty made by Seller on this product. No increase or alteration, written or verbal, of the obligations of this Limited Warranty is authorized.

U.K. Patent No: GB2414551; Russ Patent No: 2353006; A.U. Patent No: 2003291108;
U.S. Patent Nos: 7,183,912; 7,399,969; 7,399,970; China Patent No: 101167110;
Patents issued and pending worldwide. Patent information at www.surensys.com.

M-6815AM Installation Instructions

1: Mounting Location

A. Wall mounting:

1. Sensor base fastened flat on vertical wall (± 2 degrees)

B. Bracket mounting:

1. Bracket fastened to semi-vertical surface (± 15 degrees)
2. Sensor on bracket in vertical position (± 2 degrees)

C. All mounting:

1. Height = 2.3 m or 3m or 4m above floor of monitored area
2. Clear line-of-sight from sensor to monitored area
Note: glass will block DFIR sensor's view; metal will block microwave sensor's view
3. Wall temperature similar to walls/floor of monitored area
4. Sensor aimed away from windows and reflected sunlight
5. Sensor aimed away from heaters or heater/cooler outlets
6. Sensor aimed so that likely intruder paths cross two views
7. Keep 6m distance to swaying objects
8. Sensors should be separated by 3m, and not facing one another

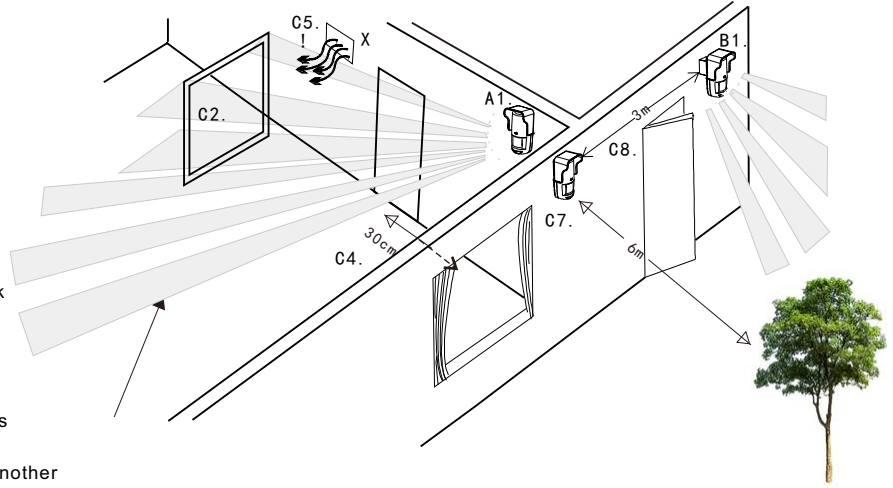

2: Sensor Disassembly

- (1) Loosen screw C1 to open front cover.
- (2) Loosen PCB mounting screws, remove PCB.
- (3) Loosen screw I1 to release internal base.

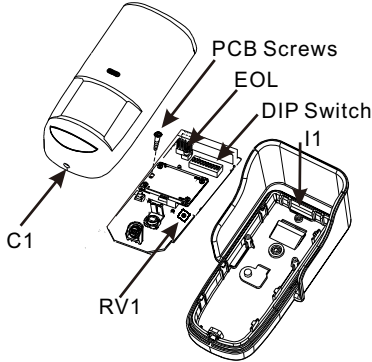

3: Base Hole Preparation

- Open base knockouts as required.
- S1-S4: Screw knockouts for the mounting bracket.
 - W1/W2: Wire-entry knockouts.
 - B1-B4: Wall-mounting knockouts.
 - B5-B8: Corner-mounting knockouts.
 - T1: Wall tamper-switch knockout.

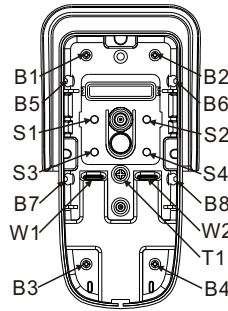

4: Base/Wall tamper Switch

For base to inner-housing tamper detection, install as in a. For wall to inner housing tamper detection, remove knockout T1 and provide screw in wall as in b. Adjust screw height to 4.5mm out from wall.

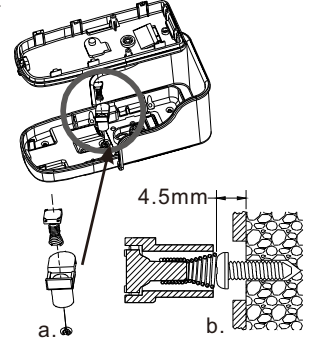

5: Mounting

Use screws to mount on wall or in corner.

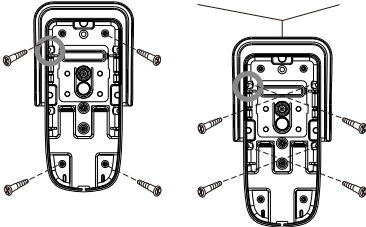

Set circuit board graduation in position "2.3m" or "3m" or "4m" to select mounting height. Tighten PCB mounting screws.

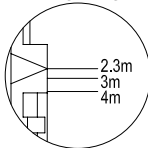

6: Bracket Mounting

Use screws to mount bracket in desired location. Use screws to mount sensor base onto bracket. Use long screw to tighten mounting bracket at desired angle. Replace internal base and circuit board, referring to 5 for setting circuit board alignment post.

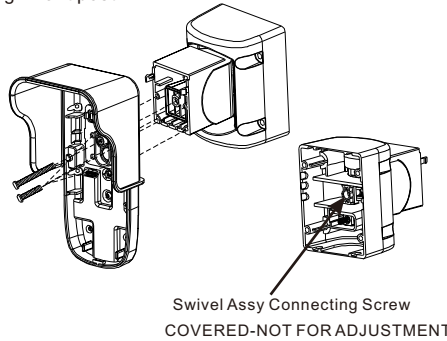

7: Wiring

Cut cable wires to appropriate length and connect wires to sensor terminal block.

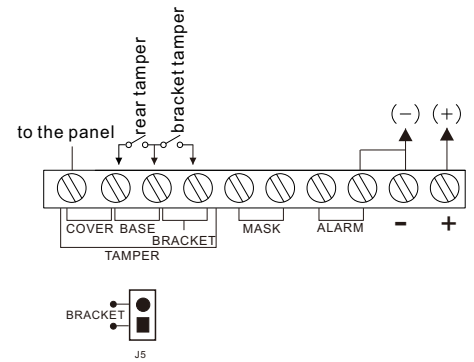

8: DIP Switch Setting

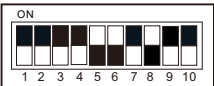

Factory Default

DIP 2: Anti Mask condition

ON: Enable
OFF: Disable

DIP 3: Anti Mask

ON: High
OFF: Standard

DIP 4: Alarm condition

ON: PIR+MW
OFF: PIR

DIP 5-6: DFIR Range setting

Range	DIP5	DIP6
6M	ON	ON
9M	OFF	ON
12M	ON	OFF
15M (Default)	OFF	OFF

DIP 7: Anti-Sway

ON: Enable
OFF: Disable

DIP 8-9: PIR Sensitivity

Sensitivity	DIP8	DIP9
High	ON	ON
Normal (Default)	OFF	ON
Mid	ON	OFF
Low	OFF	OFF

DIP 10: Red LED operation

ON: LED Enabled
OFF: LED Disabled

Microwave Adjustment

Use RV1 to adjust microwave sensitivity.

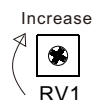

9: LED Indicator Operation

The chart below shows possible LED indications.

LED	M-6815AM	
	Sensor State	LED Display
Red	Warm-up	ON
	Test Mode	ON 5 Second
	Alarm	ON 5 Seconds (IF LED ENABLED)
	Mask	Flashing
	Normal	OFF
Yellow	MW Event	ON
	Test Mode	NO Event
Green	DFIR Event	ON
	Test Mode	NO Event