

↓

REVISIONS

ECO	Description	Checked By	Date	Engineer	Date	Eff. Date
00178	Product Release					

Notes:

1. Material: 80g printing paper, white. A4 size.
2. Printing: Black
3. Pack and tie a label with part number 0-ML00-0036-02-1.

SUREN [®] <small>Suren Systems Ltd.</small>		ITEM NO 0-ML00-0036-02-1	REV 1
APPROVALS		DATE	MANUAL, DF-5015, ENGLISH
DWN	Emily Wang	07-Jan-2011	
CHK			
ENGR			
IDENT CODE			
DO NOT SCALE DRAWING		SIZE A	SCALE 1:1
		DRAWING NO N-ML00-0036-02-1	REV 1
			SHEET 1 OF 3

↑

DF-5015 DFIR™ Motion Sensor Operation and Specifications

SUREN

The DF-5015 is a professional state-of-the-art motion sensor engineered with the world's best components and materials. Every aspect of these sensors provides the most reliable motion sensing with freedom from false alarms. The optical side starts with a EvenEye™ lens and a top-quality SUREN-designed DFIR™ infrared detector. Next, a modern microcontroller converts the infrared detector signal into digital form, for best reliability and stability. Finally, the signal is evaluated with DFIR™ anti-sway processing, for "best-in-class" false alarm rejection with excellent intruder detection.

ANTI-SWAY FUNCTION

The DF-5015 is a motion sensor, and it will normally detect swaying motion. However, the outdoor environment may contain swaying objects that are not intruders (for example, wind-blown trees). Thus, to suppress "nuisance alarms", the DF-5015 provides an "anti-sway" function to require that, before motion is indicated, a moving object must make directional progress across the sensor's fields of view. This function can be enabled or disabled by a programming jumper. Naturally, when enabled, a longer motion in front of the sensor is required before a motion Alarm is indicated. See Installation Instructions steps 8 and 9 for details.

SENSOR INITIALIZATION

Following power-on, DF-5015 sensor is fully operational after a one-minute warm-up. During warm-up, the red Alarm LED is ON.

WALK TEST

Note: The DF-5015 should be tested once per year.

In Normal Operating Mode: Enable the LEDs (JP1 ON). If the Alarm LED is not enabled, then, without removing power, set JP1 to ON. Walk across the monitored area (within the sensor's optical fields-of-view). With anti-sway disabled, and with sensitivity set at STANDARD, the red Alarm LED should turn ON (for Alarm) after about two to three normal steps. With the sensitivity set at HIGH, the LED should turn ON (for Alarm) after about one to two normal steps. Each time the LED turns ON, wait for it to turn OFF. Then, wait 12 seconds before continuing the walk-test. When there is no motion in the monitored area, the LED should remain OFF.

In Special Modes: Cycle power-off/power-on, then Walk-test immediately after warm-up in the 10-minute walk-test mode.

SUPERVISION

DF-5015 supervision functions include these tests:

- Ambient temperature in-range;
- Detector electronics okay;
- Supply voltage between 8-16Vdc;

When a failure is detected, then:

- 1) The red alarm LED blinks ON/OFF every second.
- 2) Alarm relay does not re-close after an alarm signal event.
- 3) The trouble signal output transistor turns OFF.

NOTE: The sensor will NOT initiate an alarm upon failure.

REMOTE CONTROL INPUTS

The DFIR Range input allows remote range reduction for temporary harsh environment situations. * For remote operation JP1 OFF, ** For remote operation JP2 ON. See specifications for High/Low signal levels.

DF-5015 Remote Control Inputs			
FUNCTION	High Signal	Low Signal	INPUT TYPE
Alarm LED*	ENABLE	DISABLE	Pull-down to GND
Sensitivity**	HIGH	STANDARD	Pull-up to +5V
Range	STANDARD	REDUCED	Pull-up to +5V

Limitations of Security Products: Security products and alarm systems do not offer guaranteed protection against burglary, fire, or other emergencies. They may fail to warn for diverse reasons, including (but not limited to): power failure, dead batteries, improper installation, coverage "blind spots", coverage areas overlooked during installation, defeat by technically sophisticated intruders, component failure, or inadequate maintenance. Alarm systems should be checked weekly to ensure that all devices are working properly. AN ALARM SYSTEM IS NOT A SUBSTITUTE FOR INSURANCE.

SUREN LIMITED WARRANTY

SUREN Systems, Ltd., of Fo Tan, Shatin, Hong Kong, warrants its products to be in conformance with its own plans and specifications and to be free from defects in materials and workmanship under normal use and service for twelve months from the date of original purchase. Seller's obligation shall be limited to repairing or replacing, at its option, free of charge for materials or labor, any part which is proved not in compliance with Seller's specifications or proves defective in materials or workmanship under normal use and service. Seller shall have no obligation under this Limited Warranty or otherwise if the product is altered or improperly repaired or serviced by anyone other than Seller. For warranty service, return transportation prepaid, to SUREN Systems, Ltd., Unit 15, 12/F, Block B, Wah Sang Industrial Building, 14-18 Wong Chuk Yeung Street, Fo Tan, Shatin, Hong Kong. Seller has no obligation to attend the buyer's location to retrieve the goods or make repairs on site.

There are no warranties, expressed or implied, of merchantability, or fitness for a particular purpose or otherwise, which extend beyond the description on the face hereof. In no case shall seller be liable to anyone

SPECIFICATIONS

Range: 15 meters in sensor-facing direction
15 meters at 45° angle from sensor-facing direction

Sensor Optical View Pattern (side view, in meters)

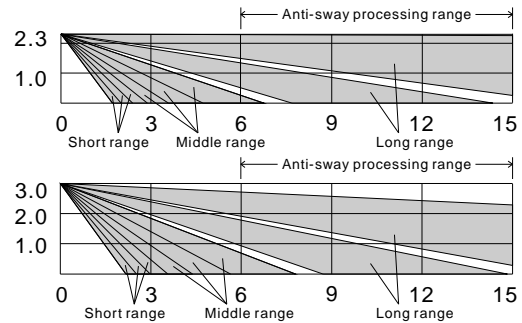

Optical Fields-of-View:

Long-range 88 Mid-range 38 Short-range 26

Sensor Optical View Pattern (top view, in meters)

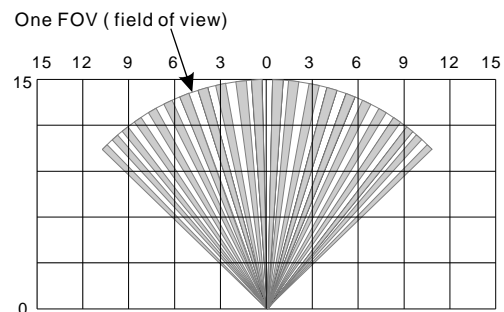

IR Sensors (2):

Dual-element + Quad-element

Power Supply:

8-16 Vdc; 30 mA at 12 Vdc

Alarm Relay:

Solid state, Form A (NC). 50 mA at 30 Vdc, 1500 V_{rms} isolation

Trouble Signal Output:

NPN open-collector to (-), 50 mA Max., NC no trouble

Remote LED Enable, DFIR

Range, DFIR Sensitivity Inputs:
Logic levels from (-): ≤1 Vdc=LOW; ≥3Vdc=HIGH; Max.=16 Vdc

Tamper Switches (cover/wall):

Form A (NC). 50 mA at 30 Vdc

Housing Material:

PC housing, HDPE lens

Dimensions:

171 x 76 x 61 mm (H x W x D)

Approvals/qualification:

CCC (Pending)
CE (Pending)

Events Detection:

DFIR™ anti-sway false alarm rejection processor

RF Immunity:

20 V/m, 10-1000 MHz;
10 V/m, 1-2 GHz

White Light Immunity:

25000 lux

Sensitivity: DFIR

Selectable: short-walk or long-walk

Operating Temperature Range:

-30°C to +55°C (-22°F to +131°F)

Accessories:

Mounting bracket:
MB-200

Note: Specifications are subject to change without notice.

for any consequential or incidental damages for breach of this or any other warranty, express or implied, or upon any other basis of liability whatsoever, even if the loss or damage is caused by its own negligence or fault.

Seller does not represent that the products it sells may not be compromised or circumvented; that the products will prevent any personal injury or property loss by burglary, robbery, fire or otherwise; or that the products will in all cases provide adequate warning or protection. Customer understands that a properly installed and maintained alarm system may only reduce the risk of a burglary, robbery, or fire without warning, but it is not insurance or a guarantee that such will not occur or that there will be no personal injury or property loss as a result.

Consequently, seller shall have no liability for any personal injury; property damage or other loss based on a claim the product failed to give any warning. However, if seller is held liable, whether directly or indirectly, for any loss or damage arising under this limited warranty or otherwise, regardless of cause or origin, seller's maximum liability shall not in any case exceed the purchase price of the product, which shall be the complete and exclusive remedy against seller.

This warranty replaces any previous warranties and is the only warranty made by Seller on this product. No increase or alteration, written or verbal, of the obligations of this Limited Warranty is authorized.

U.K. Patent No: GB2414551; Russ Patent No: 2353006; A.U. Patent No: 2003291108;
U.S. Patent Nos: 7,183,912; 7,399,969; 7,399,970; China Patent No: 101167110;
Patents issued and pending worldwide. Patent information at www.surensys.com.

DF-5015 Installation Instructions

1: Mounting Location

A. Wall mounting:

1. Sensor base fastened flat on vertical wall (± 2 degrees)

B. Bracket mounting:

1. Bracket fastened to semi-vertical surface (± 15 degrees)
2. Sensor on bracket in vertical position (± 2 degrees)

C. All mounting:

1. Height = 2.3 m or 3m or 4m above floor of monitored area
2. Clear line-of-sight from sensor to monitored area

Note: glass will block DFIR sensor's view

3. Wall temperature similar to walls/floor of monitored area
4. Sensor aimed away from windows and reflected sunlight
5. Sensor aimed away from heaters or heater/cooler outlets
6. Sensor aimed so that likely intruder paths cross two views
7. Keep 6m distance to swaying objects

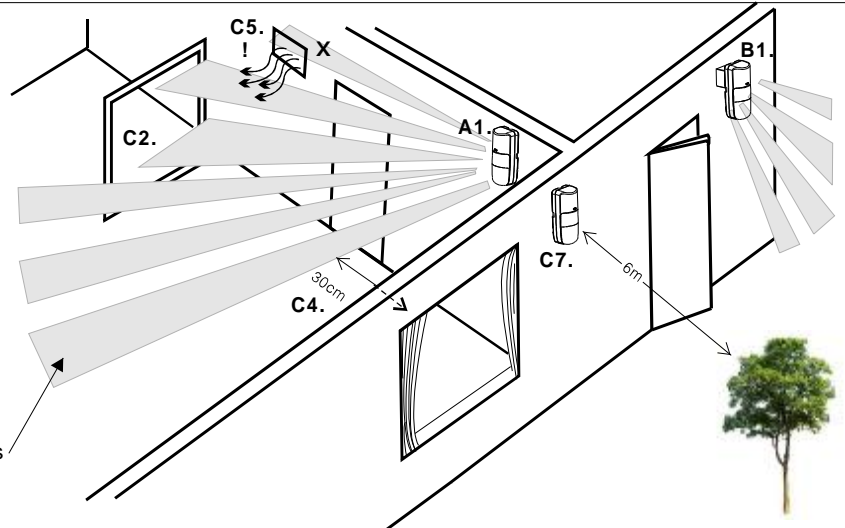

2: Sensor Disassembly

- (1) Loosen screw C1 to open ianitor™ front cover.
- (2) Loosen PCB mounting screws, remove PCB.
- (3) Loosen screw I1 to release internal base.

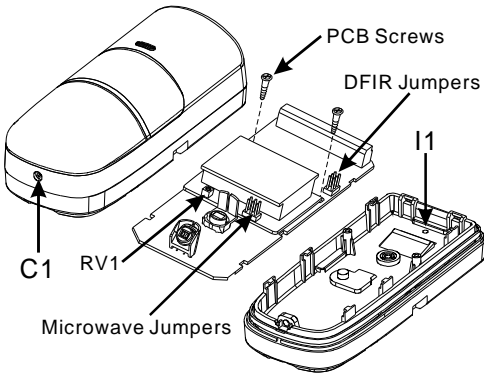

3: Base Hole Preparation

Open base knockouts as required.

- S1-S4: Screw knockouts for the mounting bracket.
- W1/W2: Wire-entry knockouts.
- B1-B4: Wall-mounting knockouts.
- B5-B8: Corner-mounting knockouts.
- T1: Wall tamper-switch knockout.

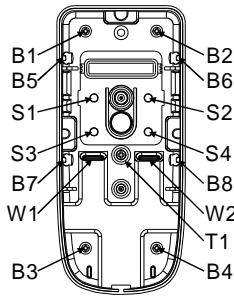

4: Base/Wall tamper Switch

For inner-housing tamper detection, install as in a. For wall-tamper detection, remove knockout T1 and provide screw in wall as in b. Adjust screw height to 4.5mm out from wall.

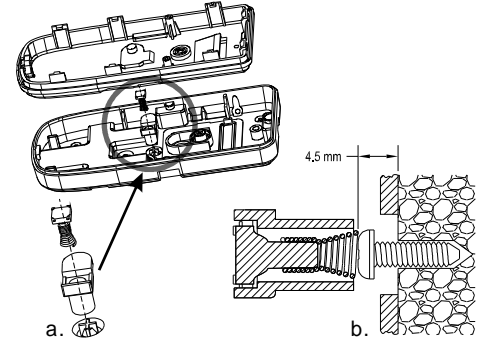

5: Mounting

Use screws to mount on wall or in corner.

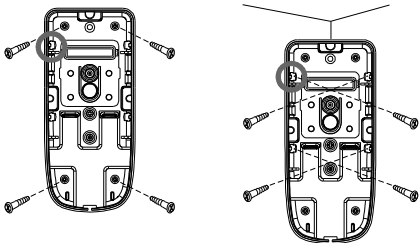

Set circuit board graduation in position "2.3m" or "3m" or "4m" to select mounting height. Tighten PCB mounting screws.

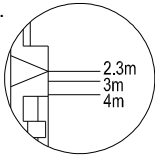

6: Bracket Mounting

Use screws to mount bracket in desired location. Use screws to mount sensor base onto bracket. Use long screw to tighten mounting bracket at desired angle. Replace internal base and circuit board, referring to 5 for setting circuit board alignment post.

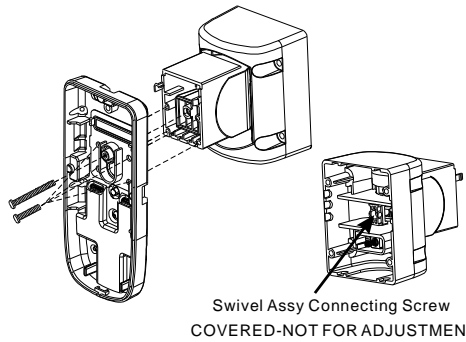

7: Wiring

Cut cable wires to appropriate length and connect wires to sensor terminal block.

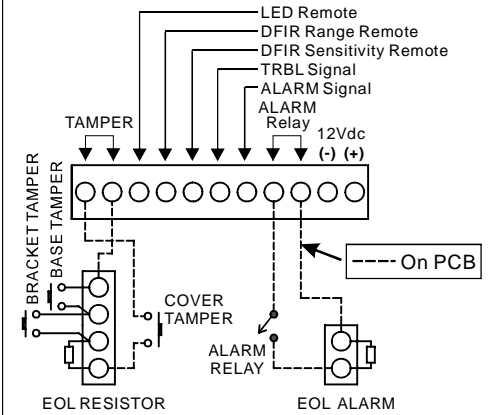

8: Operation Programming Jumpers

Set JP1 to enable or disable Alarm LED. If there is a way for intruders to pass only a very short distance in the sensor's view, or if aggressive detection is required, then use high sensitivity (JP2 OFF). Otherwise, standard sensitivity (JP2 ON) is fine for ordinary applications. Set JP3 to enable or disable Anti-Sway. Factory-set jumper positions are shown below in gray. * Position for remote control.

DF-5015 DFIR Jumpers

FUNCTION	JP	ON	OFF
Anti-Sway	3	ENABLE	DISABLE
Sensitivity	2	STANDARD*	HIGH
Alarm LED	1	ENABLE	DISABLE*

9: DFIR Motion Sensitivity

When a person walks across the sensor's fields-of-View, detection occurs after a number of steps, according to JP2 and JP3 settings.

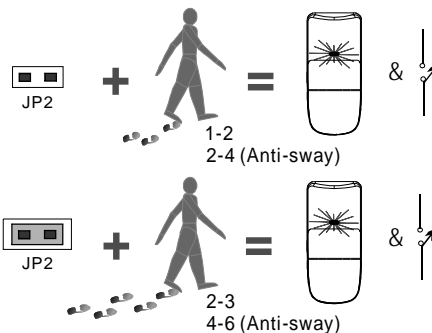

10: LED Indicator Operation

The chart below shows possible LED indications.

DF-5015	
Sensor State	LED Display
Warm-up	ON
Alarm	ON 3-6 Seconds (IF LED ENABLED)
Normal	OFF